

STRUCTURALLY CERTIFIED

ITEM No.	QTY.	DESCRIPTION	MATERIAL OPTIONS
1	1	TOP POLE SECTION - PLAIN	STEEL / HOT-DIP GALVANISED ALUMINIUM
2	1	Maxis™ M2 JOINT	STEEL / HOT-DIP GALVANISED
3	1	BASE POLE SECTION - SLOTTED - SUPPLIED WITH CABLE SLOT GROMMETS	STEEL / HOT-DIP GALVANISED ALUMINIUM

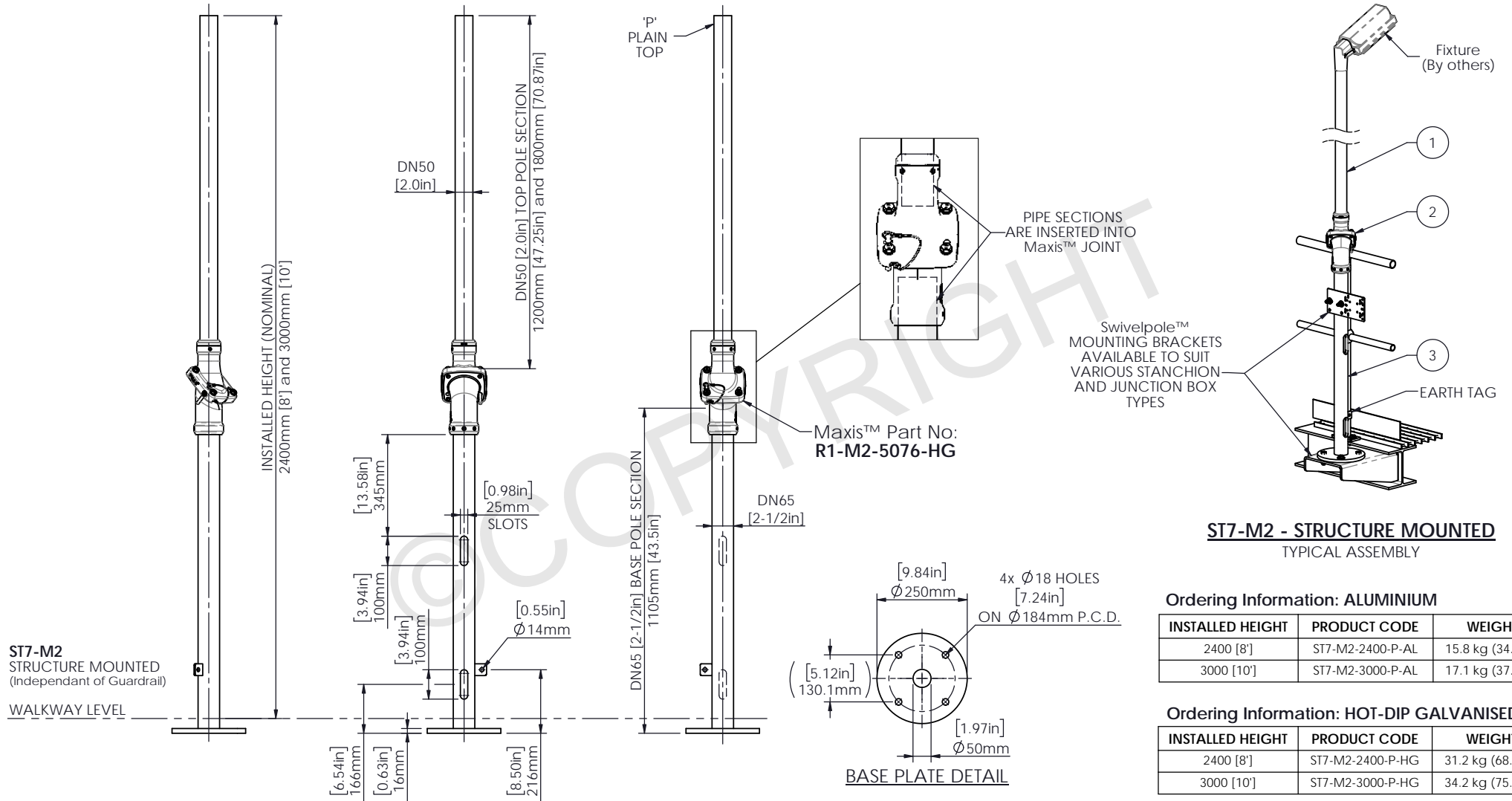

IEC



Scan Code with QR Reader app for more Swivelpole™ Solutions

maxis
PATENTED PRODUCTS

www.maxisjoint.com

PATENTED
PRODUCTS

www.swivelpole.com

Swivelpole

This document is the property of and protected by copyright owned by Swivelpole Group Pty Ltd and/or Exemplar Products Pty Ltd. The designs and other information embodied in this document comprise confidential information of Swivelpole Group Pty Ltd and/or Exemplar Products Pty Ltd and form part of products covered by international patents and registered designs including US patent No 6957832 and US patent No 9945143. Unauthorised use, reproduction and disclosure are strictly prohibited. This document must not be removed from the premises of the licensed user of this document without Swivelpole Group Pty Ltd's and/or Exemplar Products Pty Ltd's prior approval.

ALL DIMENSIONS ARE IN MILLIMETERS / INCHES		SERIES / CODE	PART NUMBER
		ST	As Noted (RQ1848 - 02/03/23)
DRAWN BY	BP	DATE	07/09/20
CHECKED BY	KM	DATE	08/09/20
APPROVED BY	AI	DATE	09/09/20
THIRD ANGLE PROJECTION	SCALE	N.T.S.	DRG No
			C-IEC-ST7-M2-6550-P-(HG-AL)
			REV 3
			A3

STRUCTURALLY CERTIFIED

ITEM No.	QTY.	DESCRIPTION	MATERIAL OPTIONS
1	1	TOP POLE SECTION - PLAIN	316 STAINLESS STEEL
2	1	Maxis™ M2 JOINT	316 STAINLESS STEEL
3	1	BASE POLE SECTION - SLOTTED - SUPPLIED WITH CABLE SLOT GROMMETS	316 STAINLESS STEEL

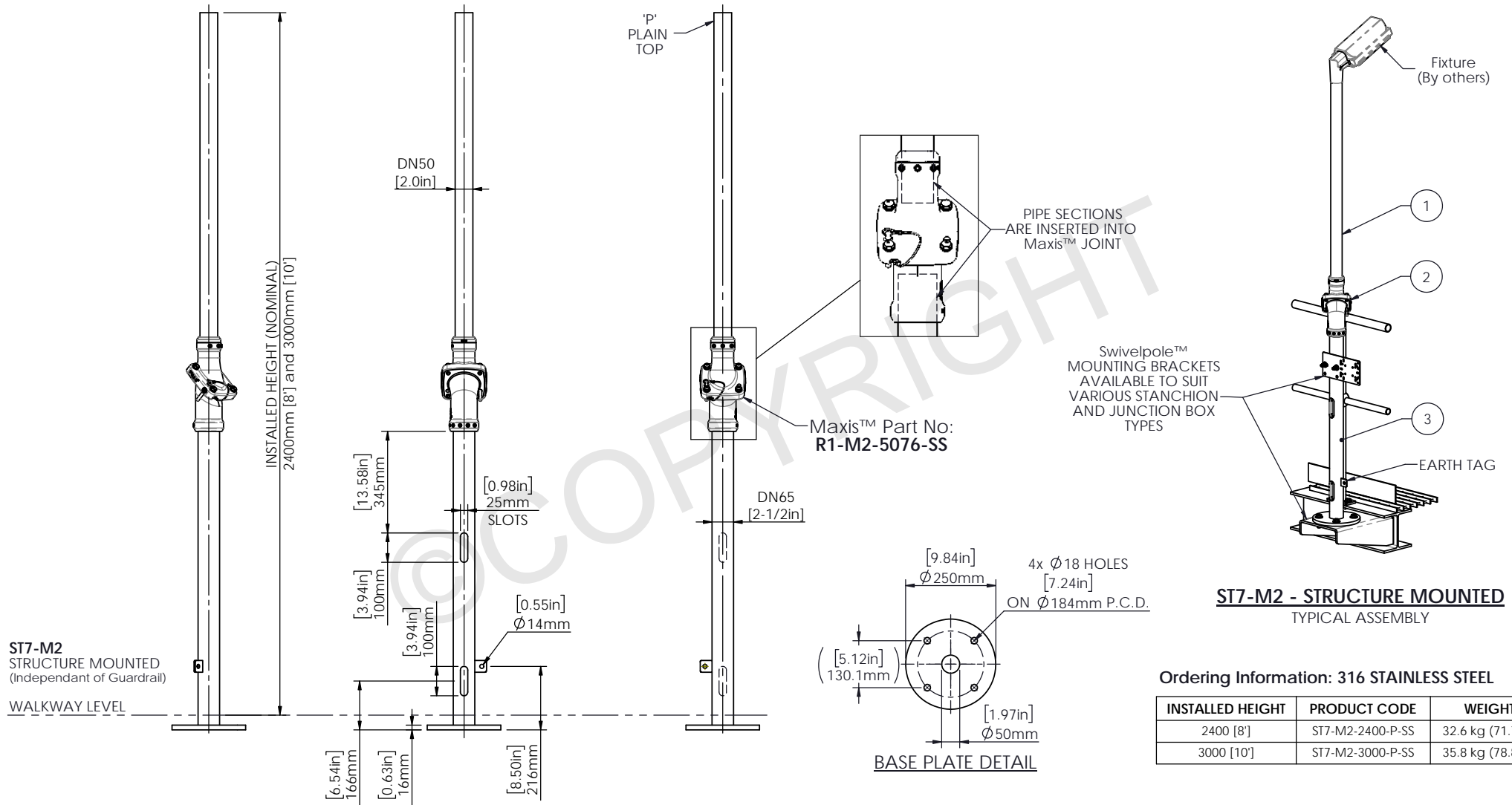

IEC



Scan Code with
QR Reader app for more
Swivelpole™ Solutions

maxis
PATENTED
PRODUCTS

www.maxisjoint.com

swivelpole
PATENTED
PRODUCTS

www.swivelpole.com

swivelpole

This document is the property of and protected by copyright owned by Swivelpole Group Pty Ltd and/or Exemplar Products Pty Ltd. The designs and other information embodied in this document comprise confidential information of Swivelpole Group Pty Ltd and/or Exemplar Products Pty Ltd and form part of products covered by international patents and registered designs including US patent No 6957832 and US patent No 9945143. Unauthorised use, reproduction and disclosure are strictly prohibited. This document must not be removed from the premises of the licensed user of this document without Swivelpole Group Pty Ltd's and/or Exemplar Products Pty Ltd's prior approval.

ALL DIMENSIONS ARE IN MILLIMETERS / INCHES		SERIES / CODE	PART NUMBER
		ST	As Noted
DRAWN BY	KM	DATE	21/04/23
CHECKED BY	AI	DATE	21/04/23
APPROVED BY	AO	DATE	21/04/23
THIRD ANGLE PROJECTION	SCALE	N.T.S.	DRG No
			C-IEC-ST7-M2-6550-P-SS
			REV 0
			A3

Swivelpole™ ST7 - Maxis™ M2
Base Section - Slotted - Top Section - Plain
General Assembly